

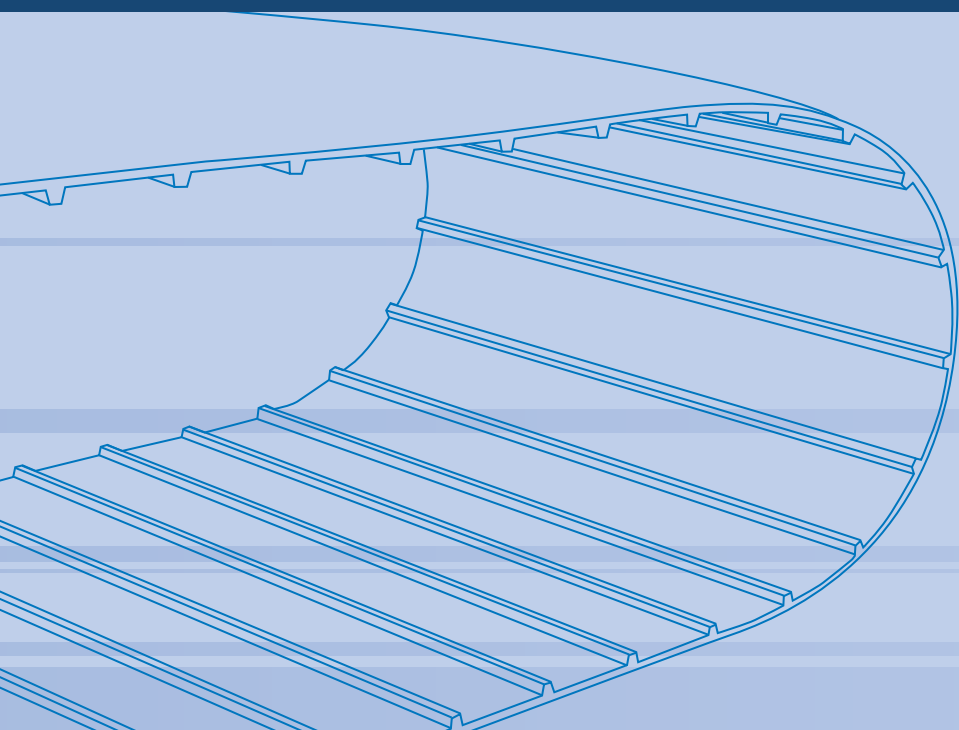

TECHNICAL DATA

DualDrive™



The Next Step in Belting



TECHNICAL DATA

FMW/FMB - 3 DUAL DRIVE™

The DualDrive™ is a homogeneous positive drive belt driven by sprockets. The full width integrated teeth which were formed during production are located on the drive side. This in turn, maintains a smooth drive and conveying surface. The DualDrive™ belt can be driven either with VOLTA sprockets or standard modular 2" Series sprockets. We recommend using our sprockets for best performance and longevity. Installation is easy and quick. Even better, DualDrive™ has all the benefits of thermoplastic homogeneous hygiene belts.

Table 1: FMW/FMB - 3 DualDrive™ Technical Data

Product	VOLTA FMW -3- DD	VOLTA FMB -3- DD
Description	Flat Solid	Flat Solid
Material	VOLTA MW, Beige	VOLTA MB, Blue
Food contact approvals	FDA / USDA / 3A Dairy	FDA / USDA / 3A Dairy
Hardness	53 D	53 D
Working temp range	-20 c to 60 °C	-20 c to 60 °C
	- 5 F to 140 °F	- 5 F to 140 °F

Coefficient of Friction (f _s) Dry	
Steel	0.5
S.Steel	0.5
UHMW	0.28

Table 2: Dimensions of Standard Pulleys

VOLTA Sprockets	6 TEETH	8 TEETH	10 TEETH	12 TEETH
Standard sprocket pitch diameter	96.4 mm (3.79")	128.6 mm (5.06")	160.7 mm (6.32")	202.9 mm (7.99")
Pulley outside diameter	93.4 mm (3.67")	125.6 mm (4.94")	157.7 mm (6.2")	189.9 mm (7.47")
Standard bore size (square)	1.5" / 40 mm	1.5" / 40 mm	1.5" / 40 mm	1.5" / 40 mm

■ Recommended modular sprockets:

8 Teeth 5.2" (132 mm) Pitch Diameter

10 Teeth 6.5" (165 mm) Pitch Diameter

* For different sprocket sizes - Contact your local VOLTA distributor.

Table 3: Technical Information

	Metric	English
Belt weight	4.15 kg/m ²	0.85 lb/ft ²
Max pull force	6 kg/cm width	33.6 lb/in width
Standard width	1524 mm	60"
Standard drive and tail pulley width	38 mm	1.5"
Standard support pulley width	38 mm	1.5"
Min. pulley diameter	80 mm	3¼"
Min. pulley for back bending	100 mm	4"

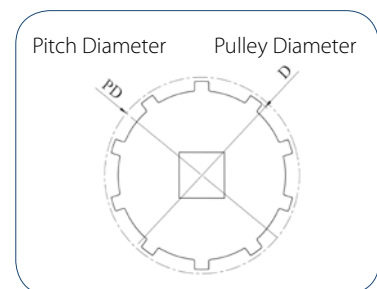

Fig 1: Pulley Dimensions

TECHNICAL DATA

FMW/FMB - 3 DUAL DRIVE™

Pretension

In most applications, the DualDrive™ belt does not require pretensioning. For heavy loads we recommend small pretension (up to 0.5%).

Recommended Conveyor Structure

- Slide bed with longitudinal strips made of UHMW in order to assure low coefficient of friction.
- UHMW wall strips to prevent belt off-tracking.
- Support rollers/strips on the return side of the belt (slack side).
- Volta Drive Pulley and Volta Tail Pulley every 4" - 6" (100-150 mm) between centers, according to the load.
- Sprockets without teeth can be used on the tail side.
- The belt should not exceed more than 2" (50 mm) from the outermost UHMW strip.
- We recommend using a tension device and a snub roller.

Table 4: Guidelines for Fabricated VOLTA FMW-3-DD / FMB-3-DD Preliminary

Pulley	125.6 mm (4.94")	157.7 mm (6.2")
Number of teeth	8	10
V - Cleat		
Electrode	+	+
VL - 10	+	+
VL - 13	+	+
VL - 17	NR	NR
Flat cleat		
Single electrode 7	+	+
Single electrode 9	+	+
Double electrode 7	+	+
Double electrode 9	NR	NR
Side walls		
SWW - 20	+	+
SWW - 30	+	+
SWW - 40	+	+
SWW - 50	+	+
SWW - 60	+	+
SWW - 80	NR	+

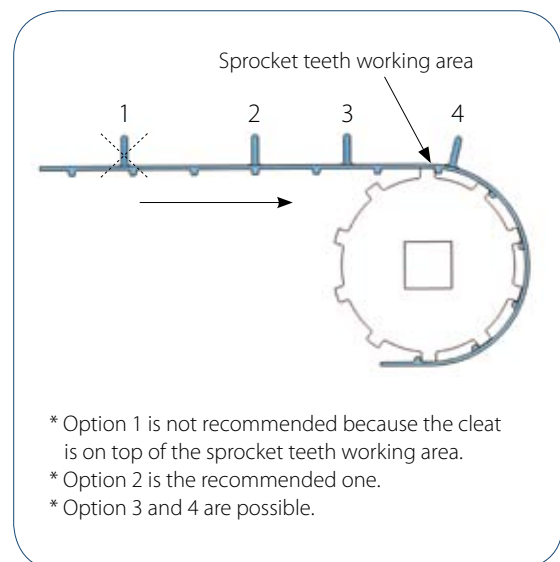

- * Option 1 is not recommended because the cleat is on top of the sprocket teeth working area.
- * Option 2 is the recommended one.
- * Option 3 and 4 are possible.

Fig 2: Recommended Cleat Welding Location

1. (+) We recommend welding the cleats top of the teeth location and not exceeding on top of the sprocket teeth working area.
2. (NR) Not recommended.



TECHNICAL DATA

FMW/FMB - 3 DUAL DRIVE™

Belt Selection Procedure

1. Calculate the belt Pull Force (horizontal transport):

$$F = fs*(G1+G2) + fr*(G2+G3) + 0.25*G4$$

F = Pull Force (kg) or (lb)

fs = Coefficient of friction of belt on slide bed

fr = Coefficient of friction of return rollers (bearings = 0.03 / bushing = 0.1)

G1 = Maximum load on the conveyor (kg) or (lb)

G2 = Belt weight (one direction) (kg) or (lb), (1/2 of total belt length)

G3 = Weight of supporting rollers (kg) or (lb)

G4 = Maximum accumulated weight (kg) or (lb)

2. Calculated the allowed pull force (Fa) according to number of teeth in mesh:

If number of teeth in mesh is five or less, an adjustment must be made to the max pull force.

Multiply the max pull force by K factor.

Table 5: K factor

Teeth in Mesh	K factor	Comment
6 or more	1	(180° Arc of contact at standard 150 mm/6" pulley)
5	0.8	
4	0.6	(180° Arc of contact at standard 100 mm/4" pulley)

$$Fa = F \times K$$

Fa = Allowed Pull Force

3. Choose the belt width

Divide the calculated pull force by the belt width to get the pull force per unit width.

Check that the calculated pull force per unit width is less than the maximum.

Allow Pull Force according to number of teeth in mesh for the belt (Fa).

TECHNICAL DATA

FMW/FMB - 3 DUAL DRIVE™

Example:

An UHMW slide bed conveyor transporting meat packages horizontally.
Check if 18" belt (457 mm) is good for this application.

Given	English-Imperial	Metric
Package weight:	30 (lbs)	13.6 (kg)
Maximum number of packages on belt:	30	30
Conveyor length:	50 (ft)	15.2 (m)
Return rollers weight (bushing):	10 (lbs)	4.5 (kg)
Number of return idlers:	6	6
Pulley diameter:	152 mm	6"
Number of teeth in mesh:	6	6

Procedure

Calculate the Pull Force:

Maximum load:	$G1 = 30 * 30 = 900$ (lbs)	$G1 = 30 * 13.6 = 408$ (kg)
Belt weight - one direction:	$G2 = 0.85 * (18/12) * 50 = 63.75$ lbs	$G2 = 4.15 * 0.457 * 15.2 = 28.82$ kg
Return idler weight:	$G3 = 6 * 10 = 60$ (lbs)	$G3 = 6 * 4.5 = 27$ (kg)
Accumulated weight :	$G4 = 0$	$G4 = 0$
	$F = fs*(G1+G2) + fr*(G2+G3) + 0.25*G4$	
	$F = 0.28 * (900 + 63.7) + 0.1 * (63.7 + 60)$	$F = 0.28 * (408 + 28.8) + 0.1 * (28.8 + 27)$
	$F = 282.2$ (lbs)	$F = 127.9$ (kg)

Allow Pull Force according to number of teeth in mesh :

For 10 teeth sprockets at 180° Arc of contact - 5 teeth in mesh

$$K = 0.8 \text{ (5 teeth in mesh)}$$

Maximum allowed belt load:	$Fa = 0.8 * 33.6 = 26.8$ (lb/in)	$Fa = 0.8 * 6 = 4.8$ (kg/cm)
	$F(\text{max}) = 26.8 * 18 = 482.4$ (lbs)	$F(\text{max}) = 4.8 * 45 = 216$ (kg)
Belt width:	18" belt width (45 cm) is ok (the calculated Pull Force is less than the allowed Pull Force)	

Positive Drive
DualDrive™



VOLTA Belting Technology Ltd.

MAIN OFFICE (ISRAEL)

Tel: +972-4-995-1333
Fax: +972-4-995-1366

USA

Tel: +1-973-276-7905
Fax: +1-973-276-7908
Tol Free: 1-877-VOLTAUS

EUROPE

Tel: +31-33-495-1800
Fax: +31-33-495-1812

www.voltabelting.com

e-mail: sales@voltabelting.com