

VOLTA Belting Technology Ltd.

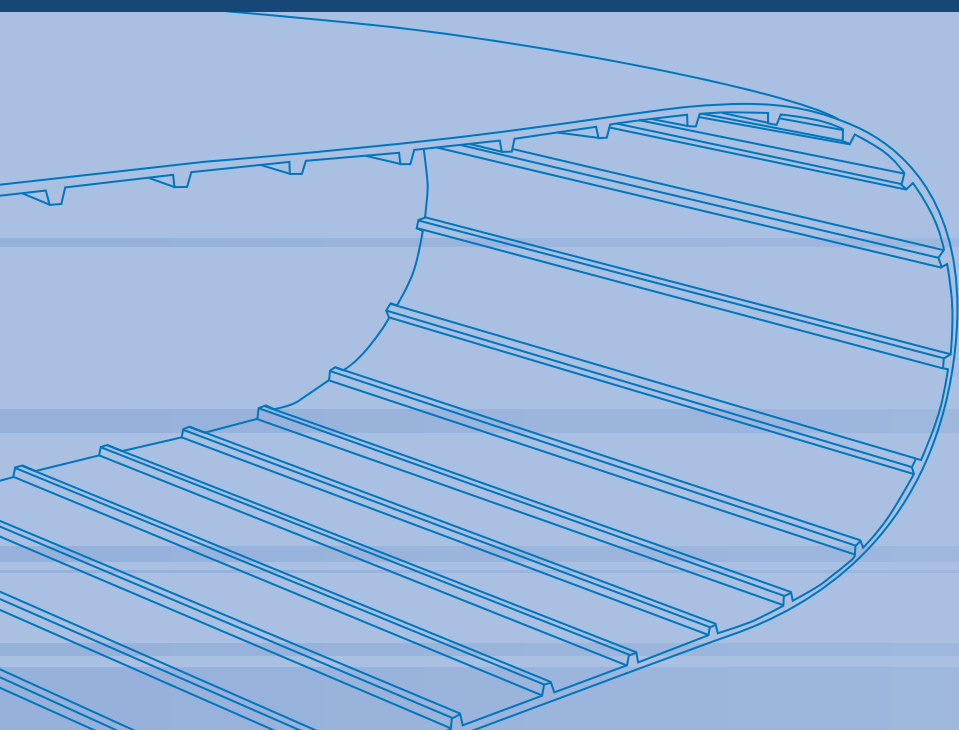

Positive Drive

DualDrive™

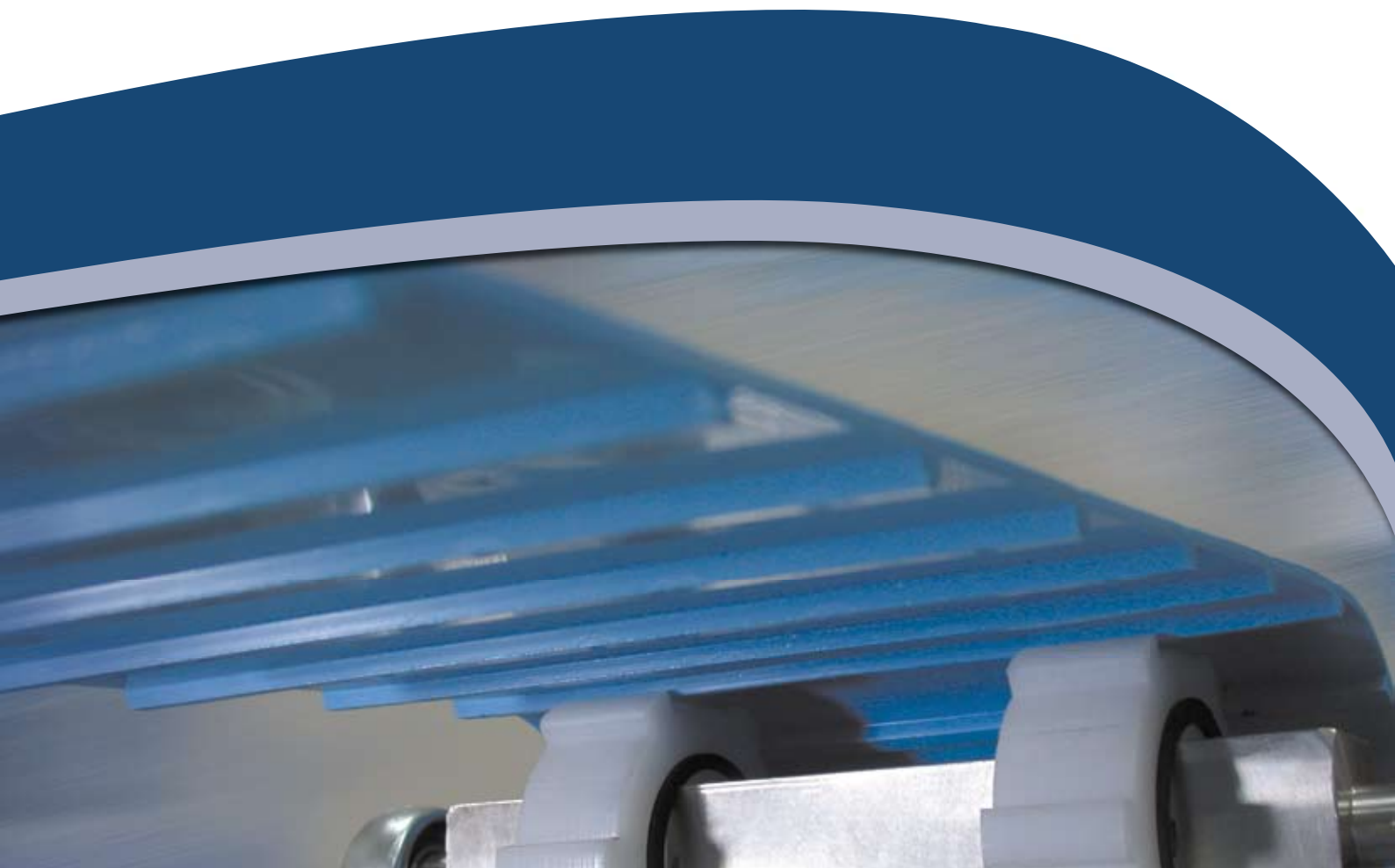

The Next Step in Belting

DualDrive™ joins the SuperDrive™ belt as the first choice conveyor belts for Hygienic, Positive-Drive requirements.

Produced as a continuous product

- No cracks or crevices on either the conveying or drive sides for maximum cleanliness
- No seams - the belt is extruded in 30 m (100') lengths without factory splicing

Homogeneous structure

- Eliminates modular components that require extensive cleaning and lengthy soaking
- Reduces the use of water and chemicals for cleaning
- Sanitation time is drastically reduced
- Eliminates need for high pressure spraying
- Greatly reduced noise levels when compared to modular belting

Positive-Drive

- No belt pretension
- No belt slippage
- No belt elongation

The pitch of the teeth is designed to match Intralox Series 800 conveyors. DualDrive™ can replace these modular belts with no retrofit requirements on 165 mm (6.5") and 132 mm (5.2") sprockets. For other diameter pulleys please consult your local Volta distributor.

For maximum performance we recommend using Volta supplied pulleys. Our pulleys can be mounted on square shafts and locked in place using standard methods.



DualDrive™ and Intralox Series 800 pulleys



DualDrive™ and Volta supplied pulleys

	FMW-3-DD	FMB-3-DD
Description	Flat, homogeneous belt, M family	
Thickness	3 mm	3 mm
Color	beige	blue
Temp Range	-20° to 60° C / -5° to 140° F	
Food Approvals	FDA/ USDA/3A Dairy	



SYDNEY
30 Raglan Road,
Auburn, NSW, 2144
ph: (02) 9743 9955
fax: (02) 9743 9986

BRISBANE
288 Curtin Avenue West,
Eagle Farm, QLD, 4009
ph: (07) 3630 1199
fax: (07) 3630 2755

MELBOURNE
107 McEwen Road,
West Heidelberg, VIC, 3081
ph: (03) 9459 2299
fax: (03) 9459 325

www.voltabelting.com ■ e-mail: sales@brendma.com